



PUBLIC WORKS DEPARTMENT
Timm Borden, Director

CITY HALL
10300 TORRE AVENUE ~ CUPERTINO, CA 95014-3266
(408) 777-3354 ~ FAX (408) 777-3333

ADDENDUM NO. 1
2018 PAVEMENT MAINTENANCE PHASE 1 - PROJECT # 2018-101
BID OPENING: November 28, 2017
2:00 P.M.

ISSUED DATE: November 14, 2017

Engineer's Estimate - \$3,000,000.00

The following revisions are hereby made to the above referenced project.

1. Replace current Bid Schedule (pages 11-12) with revised Bid Schedule (pages 11-12) attached to this addendum
2. Replace current Technical Specifications (pages 106-128) with revised Technical Specifications (Pages 106-128F) attached to this addendum.
3. Replace current Typical Sections and Keycut Details (pages 129 to 131) with revised Typical Sections and Keycut Details (pages 129 – 131B) attached to this addendum.
4. Replace current City Standard Details (pages 132-134) with revised City Standard Details (pages 132-134B) attached to this addendum.
5. Replace current Estimated Quantities (pages 147-151) with revised Estimated Quantities (pages 147-151) attached to this addendum.

All questions regarding this project must be transmitted in writing to Roger Lee, Assistant Director of Public Works. Fax number is 408-777-3333 and email address is RogerL@cupertino.org.

Please indicate receipt of this addendum on the last page of the Proposal. Failure to do so may cause rejection of your bid.

APPROVED BY:

Timm Borden
Director of Public Works

Bidder's Name: _____

Bid Schedule

This Bid Schedule must be completed in ink and included with the sealed Bid Proposal. Pricing must be provided for each Bid Item as indicated. Items marked "(SW)" are Specialty Work that must be performed by a qualified Subcontractor. The lump sum or unit cost for each item must be inclusive of all costs, whether direct or indirect, including profit and overhead. The sum of all amounts entered in the "Extended Total Amount" column must be identical to the Base Bid price entered in Section 1 of the Bid Proposal Form.

LS = Lump Sum EA = Each LF = Linear Foot CY = Cubic Yard SY=Square Yard
 SF = Square Feet LB = Pounds TON = Ton (2000 lbs) AL = Allowance

BID ITEM NO.	ITEM DESCRIPTION	EST. QTY.	UNIT	UNIT COST	EXTENDED TOTAL AMOUNT
1	Traffic Control	1	LS	\$	\$
2	Leveling Course -No. 4 Hot Mix Asphalt Type A	4,107	TON	\$	\$
3	Hot Mix Asphalt, 1/2" Maximum Type A	17,694	TON	\$	\$
4	Pavement Fabric	151,575	SY	\$	\$
5	Keycut A	71,018	LF	\$	\$
6	keycut B	5,750	LF	\$	\$
7	Dig Out 6" AC	841	SY	\$	\$
8	Adjust Survey Monument Cover to Finish Grade	155	EA	\$	\$
9	Lower Manhole Covers Prior to Cold Planing	51	EA	\$	\$
10	Lower Cleanout / Water / Gas Valve Cover Prior to Cold Planing	26	EA	\$	\$
11	Adjust Manhole Covers to Finish Grade	200	EA	\$	\$
12	Adjust Cleanout / Water / Gas Valve Cover to Finish Grade	29	EA	\$	\$
13	Install Blue RPM's @ Fire Hydrant	48	EA	\$	\$
14	6" White Lines (Thermo)	210	LF	\$	\$
15	12" White Hatch (Thermo)	140	LF	\$	\$
16	12" White Crosswalk/Limit Line (Thermo)	1,540	LF	\$	\$
17	12" Yellow Crosswalk (Thermo)	300	LF	\$	\$
18	24" White (Thermo)	410	LF	\$	\$
19	24" Yellow (Thermo)	210	LF	\$	\$
20	Striping Detail # 22 (Thermo & Markers)	5,550	LF	\$	\$
21	Striping Detail 38 (Thermo & Markers)	40	LF	\$	\$
22	Striping Detail # 40A (Thermo)	40	LF	\$	\$
23	"Ahead Legend" Yellow (Pre-formed thermo)	3	EA	\$	\$
24	"STOP" Legend (Pre-formed Thermo)	39	EA	\$	\$

Bidder's Name: _____

BID ITEM NO.	ITEM DESCRIPTION	EST. QTY.	UNIT	UNIT COST	EXTENDED TOTAL AMOUNT
25	"SLOW" Legend (Pre-formed Thermo)	1	EA	\$	\$
26	"SCHOOL" Legend (Pre-formed Thermo)	1	EA	\$	\$
27	"XING" Legend (Pre-formed Thermo)	1	EA	\$	\$
28	"25" Legend (Pre-formed Thermo)	11	EA	\$	\$
29	"YIELD" Legend (Pre-formed Thermo)	2	EA	\$	\$
30	"BUMP" Legend (Pre-formed Thermo)	12	EA	\$	\$
31	Green Bike Lane (Pre-formed Thermo)	1,500	SF	\$	\$
32	Bike Rider Symbol Left Facing (Pre-formed white on green)	1	EA	\$	\$
33	Bike Rider Arrow (Pre-Formed white on green)	1	EA	\$	\$
34	Arrow Type III (Pre-formed Thermo)	1	EA	\$	\$
35	Arrow Type IV (Pre-formed Thermo)	8	EA	\$	\$
36	Replace Traffic Signal Loops	28	EA	\$	\$
37	Remove/Install Speed Bump (Modified City detail 17-A 12' section)	7	EA	\$	\$
38	Type D HMA Dike	150	LF	\$	\$
39	Type E HMA Dike	780	LF	\$	\$
40	Remove Existing 4" Shoulder/Replace with 4" HMA	3984	SF	\$	\$
41	Regrade Shoulder to Drain	300	SF	\$	\$
42	Shoulder Backing	1200	SF	\$	\$

TOTAL BASE BID: Items 1 through 42 inclusive: \$ _____

Note: The amount entered as the "Total Base Bid" should be identical to the Base Bid amount entered in Section 1 of the Bid Proposal form.

BIDDER NAME: _____

END OF BID SCHEDULE

TECHNICAL SPECIFICATIONS

1. TRAFFIC CONTROL (Bid Item Number 1)

a. Item Requirement

Contractor shall furnish all necessary supervision, labor, materials, construction tools and equipment, supplies to complete traffic control at each location during the times immediately prior, during and after work.

b. Scope

Construction area signs shall be furnished, installed, and removed when no longer required. The Contractor's attention is directed to Section 7-1.08, "Public Convenience", Section 7-1.09, "Public Safety", and Section 12, "Construction Area Traffic Control Devices", of the Caltrans Standard Specifications and Section 00820 Traffic Control Requirements of these specifications.

All traffic control devices shall conform to the latest "Manual of Traffic Control for Construction and Maintenance Work Zones" issued by Caltrans.

(a) Advance construction warning signs shall be placed on all streets leading into the construction area before any construction is started.

(b) Speed limit advisories may be placed along the main traffic lanes.

(c) When detours or changes in traffic lanes are required, directional signs shall be placed at each end and along the road

(d) Warning signs, caution signs, and end construction signs, shall be placed at each end of the work and along the route when conditions warrant their use.

(e) When asphalt keycuts remove any portion of a bike lane, warning signs including bike lane closed ahead, uneven pavement, and share the road signs shall be placed to provide advanced warning to bicyclists. The signs shall remain in place until final paving is complete and bike lane striping is replaced.

The Contractor shall submit a detailed traffic control plan for all work that requires lane closures at least 5 days prior to the lane closure. No lane closure will be allowed without prior approved traffic control plan specific to that location.

The Contractor is responsible for proper placement and maintenance of all signs and barricades. Any additional signs, barricades, lights, etc., that may be required by the Engineer to ensure public safety shall be installed and maintained by the Contractor.

Note: Traffic Controls – Qualified Individual: Traffic controls through the construction zone shall be designed and maintained by a designated individual qualified in this responsibility. **The Contractor shall submit the traffic control plan and have an approved traffic control plan prior to commencing work. Traffic control shall be planned for each individual lane closure with detail layouts of all signage locations. For all other locations, Contractor shall provide traffic control plan indicating each specific street(s) to be worked on a daily basis and warning signage to be placed on adjacent streets to warn public of work areas.**

If required in the traffic control plan, and always during one way traffic control, flagmen will be required to direct traffic during construction. The number and location of flagmen shall be sufficient to allow safe control and passage of traffic through the work zone. During the paving of intersections, two flagmen shall be posted at each intersection for the entire time between tack coat and finish rolling.

If a cross street needs to be temporarily closed when work is in progress through the intersection and the anticipated delay is more than five minutes, a detour sign shall be installed on the cross street and shall include the installation of advance signing displaying the anticipated delay time. The signing shall be reviewed by the Traffic Engineer.

Contractor shall supply **two (2)** programmable message boards per arterial / collector street a minimum of one week in advance of any work at designated locations as advanced information signs. The message shall be pre-approved by the Engineer prior to programming.

The term “Construction Area Signs” shall include all temporary signs required for the direction of public traffic through or around the work during construction. Such signs are shown in or referred to in the current MANUAL OF TRAFFIC CONTROLS – Warning signs, Lights and Devices for Use in Performance of Work Upon Highways, published by the State of California, Department of Transportation, hereinafter referred to as MANUAL OF TRAFFIC CONTROLS.

Restrictions on Closure of Traffic Lanes

The streets shall be open for use by public traffic on Saturday, Sunday, and any day designated by the City as a legal holiday; before 8 a.m. and after 5 p.m., Monday thru Friday, or any day preceding a designated legal holiday; and when construction operations are not actively in progress on working days. During daily construction operations, there may be certain peak traffic hours that would require the Contractor to alter the construction schedule in order to minimize the impact of the work on the public’s convenience.

The following provisions shall apply on the listed street segments:

<u>Street</u>	<u>Special Traffic Control Provision</u>
<u>Arterials:</u>	Lane closures are limited to one lane at a time . The roadway shall be open for two-way traffic at all times.
<u>Other Collectors:</u> Bubb Rd, S Tantau Ave, Bandlely Dr.	On four lane streets, one lane in each direction shall be maintained at all times. On two lane streets, flagmen shall be used to maintain traffic flow.
<u>Streets Near Schools:</u> See Attachment A	Work will be limited to days when school is out of session, (June 8, 2018 – August 11, 2018
<u>Residential:</u>	Traffic may be limited to only local traffic during the period between 8 a.m. and 5 p.m. Work on Mariani shall be completed at night between the hours of 10 PM and 6 AM. Hauling of equipment and materials is prohibited within 500’ of any school between the hours of 7:00 AM and 9:30 AM and 2:00 PM and 4:00 PM. Contractor is responsible for identifying locations of schools and planning haul route accordingly.

Refer to “Attachment A” – Work Hour Restrictions for working hour requirements for each street or street category.

Attention is directed to Sections 7-1.08, “Public Convenience,” 7-1.09, Public Safety,” and 12, “Construction Area Traffic Control Devices,” of the State Standards and to the Section entitled “Public Safety” and flagging for traffic control systems elsewhere in these technical specifications. Nothing in these technical specifications shall be construed as relieving the Contractor from his responsibility as provided in said Section 7-1.09.

Lane closures shall conform to the provisions in the section of these special provisions entitled “Traffic Control for Lane Closure.”

Personal vehicles of the Contractor’s employees shall not be parked on the traveled way or shoulders, including any section closed to public traffic.

The Contractor shall notify local authorities of his intent to begin work at least 7 calendar days before work is begun. The Contractor shall cooperate with local

authorities relative to handling traffic through the area and shall make his own arrangements relative to keeping the working area clear of parked vehicles.

Whenever vehicles or equipment are parked on the shoulder within 6 feet of a traffic lane, the shoulder area shall be closed with fluorescent traffic cones or portable delineators placed on a taper in advance of the parked vehicles or equipment and along the edge of the pavement at 25-foot intervals to a point not less than 25 feet past the last vehicle or piece of equipment. A minimum of 9 cones or portable delineators shall be used for the taper. A C23 (Road Work Ahead) or C24 (Shoulder Work Ahead) sign shall be mounted on a telescoping flag tree with flags. The flag tree shall be placed where directed by Engineer.

In order to minimize the impact on local merchants, and residents, driveways shall not be blocked for any long periods of time. The Contractor shall maintain access to all driveways before and after road material is placed. The Contractor shall limit the time between the prep time placing and curing time of the asphalt material and cleanup so that vehicles may return the roadway to use.

The full width of the traveled way shall be open for use by public traffic on weekends, designated legal holidays, and when construction operations are not actively in progress.

Minor deviations from the requirements of this section concerning hours of work which do not significantly change the cost of the work may be permitted upon the written request of the Contractor if in the opinions of the Engineer public traffic will be better served and the work expedited. Such deviations shall not be adopted until the Engineer has indicated his written approval. All other modifications will be made by contract change orders.

A traffic control system shall consist of closing traffic lanes in accordance with the provisions of Section 12, "Construction Area Traffic Control Devices," of the State Standards, the provisions under "Maintaining Traffic" elsewhere in these technical specifications.

The provisions in this section will not relieve the Contractor from his responsibility to provide such additional devices or take such measures as may be necessary to comply with the provisions in Section 7-1.09, "Public Safety," of the State Standards.

If any component in the traffic control system is damaged, displaced, or ceases to operate or function as specified, from any cause, during the progress of work, the Contractor shall immediately repair said component to its original condition or replace said component and shall restore the component to its original location.

Lane closures are made for work periods only, at the end of each work period, all components of the traffic control system, except portable delineators placed along the traveled way, shall be removed from the traveled way, shoulder and auxiliary lanes.

c. Measurement & Payment

The contract lump sum price paid for Traffic Control shall include full compensation for furnishing all labor including flagging costs, materials (including signs), tools, equipment and incidentals, and for doing all the work involved in placing, removing, storing, maintaining, moving to new locations, replacing and disposing of the components of the traffic control system and preparing required traffic control plans, as specified in the State Standards and these technical specifications, and as directed by the Engineer.

2. HOT MIX ASPHALT TYPE A(Bid Item Numbers 2- 3)

a. Item Requirement

Work to be performed under this Section covers all labor, materials, tools, equipment, transportation, and incidentals necessary to construct HMA including leveling, overlay, pavement replacement, transitions and digouts.

All such work shall conform to the applicable provisions of the State of California, Department of Transportation, Standard Specifications (Caltrans) dated 2010; these Technical Specifications; and the plans and typical sections.

b. Scope

All asphalt concrete materials shall be as specified in Section 39, "Hot Mix Asphalt", of the Standard Specifications; these Technical Provisions; and the plans and typical sections.

Mix Types

Generally, the hot mix asphalt to be used will be as follows unless modified by the Engineer:

Base Courses: 3/4 inch, Type A HMA, for base courses greater than 2-1/2 inches (0.20 feet or 65 mm).

1/2 inch Type A HMA for base courses of 2-1/2 inches (0.20 feet or 65 mm) or less.

Leveling Courses: No. 4 , Type A HMA for leveling courses of 1 inch (0.06 feet or 19 mm) or less. 3/8 inch Type A HMA, for leveling courses greater than 1 inch (0.06 feet or 19 mm)-

Surface Courses: 1/2 inch, Type A HMA, for surface courses of 2-1/2 inches (0.20 feet or 65 mm) or less on residential minor collectors; surface courses less than 2 inches (0.17 feet or 50 mm) on collectors and arterials; and on all alleyways and parking lots.

3/4 inch Type A HMA for surface courses greater than 2 inches (0.17 feet or 50 mm) on collectors and arterials. At the Contractors option, 1/2- inch Type A HMA may be used for these courses.

Binder Type

The asphalt grade shall be PG 64-16 and shall conform to Subsection 92 of the Standard Specifications.

Tack Coat

Tack coat shall be utilized and will be emulsified asphalt Grade RS-1, RS-1h, SS-1, or SS-1h and shall conform to Section 94, 'Asphaltic Emulsions', of the Standard Specifications.

Contractor-Supplied Job Mix Formula (JMF)

The contractor will be required to furnish the Engineer with a JMF for each type of asphalt concrete to be used on the project. The JMF shall include a list of material sources and a Certificate of Compliance signed by the material supplier or his representative indicating that the materials to be incorporated in the work fulfill the requirements of these specifications. This submission will be provided fifteen calendar days or ten working days prior to the start of work. If requested, the contractor will also provide aggregate and binder samples or a plant produced mix sample for mix design verification. The mix designs shall be prepared by laboratories and personnel with current Caltrans or AASHTO certification.

The asphalt concrete mixtures shall conform to all of the provisions of the revised Section 39 of the Standard Specifications and to the following requirements:

For arterial and collector streets the asphalt concrete air void content shall be between 4% minimum and 5% maximum and the S-value shall be 37 or greater.

For residential streets and collectors the asphalt concrete air void content shall be between 3% minimum and 4.0% maximum and the S-value shall be 35 or greater.

As a minimum, the mix design shall indicate the percentage passing for each specified sieve, the percent of asphalt, the laboratory compacted unit weight, the theoretical unit weight (Rice Gravity), and the stability of the mix to be used for each asphalt concrete mixture to be incorporated on the project. The mix design, with allowable tolerance for a single test, shall be used for job control.

Delivery Tickets

Each delivery ticket shall include information on the material type, binder type, oil content, and the mix design number. Material delivered to the project without such annotations shall be subject to rejection.

CONSTRUCTION

Surface Preparation

The work shall consist of preparing the existing street surfaces prior to the commencement of paving. Such work shall include removing raised pavement markers, removing surface mounted concrete centerline dividers where applicable, removing thermoplastic traffic markings and legends, controlling nuisance water, sweeping, watering, and removing loose and broken asphalt concrete pavement and foreign material as specified in the Standard Specifications and these Technical Specifications, and as directed by the Engineer.

Prime Coat

No prime coat is required.

Tack Coat

Tack coat shall be applied to all existing asphalt concrete or Portland cement concrete surface to be paved over. The tack coat shall conform to the requirements in Section 39 of the Standard Specifications.

All vertical edges to be paved against shall be tack coated. These include, but are not limited to, curb faces, gutter lips, swale edges, cross gutter edges, and asphalt concrete edges. Vertical edges shall be tack coated by hand wand or manually by brush. The tack coat application shall not extend above the level of the finished surface by more than 1 inch. Gutter pans and curb faces not to be tack coated shall be protected by shields or other methods. Any overspray beyond the one inch shall be removed by means approved by the Engineer.

Tack coat shall be applied per Section 39-1.09C. The tack coat for cold planed areas shall be double that of the existing pavement or leveling courses. The cold planed areas shall be tack coated first and then recoated when the entire pavement is tack coated.

Existing curb faces and driveways shall be protected against disfigurement or discoloration from the asphalt materials including tracked tack coat. Residue of the material shall be removed from curb faces and driveways by sandblasting or other means acceptable to the Engineer. Cleaning shall be to the extent required by the Engineer.

The CONTRACTOR shall be responsible for cleaning tack coat tracked onto decorative concrete crosswalks and thermoplastic legends and crossbars within the project limits and along truck haul routes used by the CONTRACTOR or his SUBCONTRACTORS. All haul routes for the work shall be designated. The haul routes shall be inspected by the City and CONTRACTOR prior to initiating work to photographically establish the existing conditions. Within 10 calendar days of completion of final paving, the City and CONTRACTOR shall reinspect the haul routes to determine the extent and locations of required cleaning. Cleaning shall be performed within 10 calendar days after the City delivers a written copy of the locations of required cleaning. Failure to meet this schedule, whether to reinspect or to perform cleaning, shall subject the CONTRACTOR to a liquidated damage of \$100 per calendar day per locations

Cold Joints

All cold joints, both longitudinal and transverse, shall be heated with a torch immediately prior to paving. Cold joints include previous passes placed more than three hours prior. All cold joints shall be tack coated.

Leveling, Transitions, and Asphalt Concrete Fills

A leveling course of variable thickness shall be placed and compacted prior to placing the surface course at locations where directed by the Engineer. The leveling course will be used to correct pavement irregularities such as rutting, variable cross slope, or variable longitudinal slope. Where two overlays of different thickness abut at a longitudinal joint, the Contractor shall add to the thinner section to match the thicker lift and provide a smooth transition and uniform cross-fall. Cold planing ridges or other rises in the pavement surface may be required by the Engineer. The Engineer will determine the exact limits and thickness of the leveling courses, asphalt concrete fills, and transitions.

Layout

The contractor shall layout and mark the location of the edges of the paving passes of the surface course to match the new layout of the lane lines. The layout shall be made at least 24 hours prior to paving. The layout shall be approved by the Engineer prior to paving.

If the striping is to remain unchanged, the edges of the paving passes shall conform to existing lane edges.

In all cases where practical, each lane shall be paved in a single pass. In tapered transition areas, the shoulder areas shall be paved first, then the through lane shall be hotlapped immediately after the shoulder paving.

For paving which incorporates new quarterpoints or gradebreaks due to keycuts or other conditions, the contractor shall provide equipment capable of adjusting to the new surface profile at the appropriate locations. The profile adjustments shall be within twelve inches of the actual quarterpoint or gradebreak.

The contractor shall take sufficient measurements during laydown to assure that the full design asphalt concrete layer depth is provided at each quarterpoint, gradebreak, and transition. Failure to provide the design depth at these areas will result in rejection of the work. Correction of this rejected work will include milling out the new asphalt concrete from the road edge to the centerline or nearest inside lane line and repaving. The minimum length of the milled and corrected area shall be fifty feet.

Asphalt Depth

Asphalt thicknesses for arterial dig outs are 9 inches, collector dig outs are 6 inches, residential dig outs are 4 inches, cold planed fills are 4 inches, residential overlays

are 2 inches, residential leveling (followed by an overlay) are ½ inch and residential leveling (not followed by an overlay) are 1 inch.

Asphalt Dig Out – Safety

Final lift (1-3/4” minimum) shall be in place within 72 hours of removing asphalt dig outs. Once the pavement is removed in asphalt removal and replacement areas, the Contractor shall diligently prosecute the work so that the deep lift is in place within the same working day. At no time shall there be a drop off greater than 0.1' (one-tenth of a foot) in the pavement overnight. No unnecessary delays shall be tolerated. By way of ascertaining and fixing the amount of damages, and not by way of penalty, the Contractor shall pay the City the sum of three hundred dollars (\$300) per calendar day, for each excavated area that remains incomplete beyond the two calendar (2) day limit. Day one starts upon the initial removal. All liquidated damages in this Contract are cumulative.

Tolerances

The Contractor shall provide 10 or 12 foot straightedge for use by the inspector with the paving machine during paving operations. It shall be immediately available at all time that paving operations are in operation.

The finished asphalt concrete surface shall be flush with, to 1/4 inch (0.20 feet or 6 mm) above, the gutter lips. The finished pavement surface shall not be lower than the gutter lips. The completed paving shall meet the following thickness tolerances:

Digouts: +/- 0.04 feet (12.5 mm)

Leveling Courses: Average Depth +/- 0.02 feet (6 mm)

Surface Courses: Minimum Depth: 0.12 feet (50 mm), /Average Depth shall equal design depth. (Contractor shall be within 5% of computed tonnage using the product of the measured area, design depth and average compacted unit weight in place.

Rolling and Compaction

Compaction of all HMA courses 0.15 feet (1.75 inches) or greater (including digouts) shall comply with the Standard Process density requirements.

For leveling courses under, breakdown rolling shall consist of a single pass of a 8 ton (minimum) steel wheel roller, three coverages with a pneumatic roller followed by a finishing coverage with a steel wheel roller. Pneumatic rollers shall weigh between 8 and 12 tons and shall be equipped with side skirts to hold in heat. A minimum of two (2) pneumatic rollers with separate operators shall be provided. Pneumatic rollers shall have skirting to maintain the heat of tires. The three coverages of pneumatic rolling shall be completed prior to the pavement surface temperature falling below 200°F as indicated with an inferred temperature gun.

Failure to comply with this provision shall be cause to stop additional paving until the rolling is brought into compliance as indicated by the Engineer

In lieu of the core testing indicated in the revised specifications referenced above, the following shall apply: The compaction shall be computed for each lot, with a maximum lot size of 500 tons. Each street segment of less than 500 tons shall be its own unique lot. Core density/nuclear gauge shall be done per CTM 375, 'Determining the In-Place Density and Relative Compaction of Asphalt Concrete Pavement'. The average asphalt concrete density of each lot shall be between 92.5% and 96.0% of Maximum Theoretical Density. Individual test sites shall be between 91.0% and 97.0% of Maximum Theoretical Density. Core/nuclear densities shall be taken at a rate of no fewer than one core per 50 tons of mix. If compaction fails by nuclear methods, then core density/nuclear gauge correlation and/or core densities shall be used to establish compaction.

When core density is used to determine compaction, cores that fall between 91.0% and 97.0% of Maximum Theoretical Density shall be paid for by the owner. Failing cores shall be paid for by the Contractor. If the core density testing produces both passing and failing cores, the cost will be prorated between the owner and Contractor.

Compaction failing to meet the above criteria shall be subject to the payment reductions indicated in Section 39-2.03, "Reduced Payment Factors for percent of Maximum Theoretical Density and the payment shall apply to each 500 ton lot: The deductions shall be based on the average of the lot and/or reductions for individual test locations.

Drainage

The Contractor shall inspect all of the proposed paving areas for potential drainage problems related to the paving work. This inspection shall be done prior to the preconstruction meeting and a list of areas of concern shall be provided at that meeting. The Engineer will provide direction as to how each area shall be constructed for drainage. A minimum of 10 calendar days shall be provided prior to paving. Within 3 days after completion of paving, the Contractor shall provide a water truck and traffic control as necessary to test any drainage areas of concern. Drainage problems shall be corrected by the Contractor as directed by the Engineer at no additional expense. Drainage problems are defined as birdbaths greater than ¼" in depth and/or greater than 3 feet in any dimension shall be corrected. Correction of drainage problems shall use an inferred heater to heat the asphalt. HMA shall be added or removed as necessary and the area compacted using a small vibratory roller if possible or vibraplates if necessary.

c. Measurement & Payment

Payment for each bid item shall be by the ton and shall include full compensation for furnishing all labor, materials, tools, equipment, transportation, incidentals; and for doing all of the work involved in constructing asphalt concrete pavement, tack coat, complete as detailed and as specified in these Technical Specifications.

3. PAVEMENT FABRIC / PAVEMENT MAT (Bid Item Number 4)

a. Item Requirement

The work shall consist of providing and installing pavement fabric or pavement mat prior to final paving course. All such work shall conform to the applicable provisions of the State of California, Department of Transportation, Standard Specifications (Caltrans) dated 2010; these Technical Specifications; and the plans and typical sections

b. Scope

MATERIALS

Pavement Fabrics

Pavement fabrics approved for use are: Amoco 4598, Trevira 011/200, Mirafi Mirapave 500, Linq AOH, or equivalent as approved by the Engineer.

The tack coat shall be emulsified asphalt of grades RS1, RS2, SS1, or SS1h, conforming to Section 94, 'Asphaltic Emulsions', of the Standard Specifications. Tack coat for Pavement Fabrics shall be PG 70-10.

CONSTRUCTION

Preparation

The Contractor shall prepare the asphalt concrete surface by removing all extraneous materials including dirt, clay, soil, vegetation, weeds, and loose aggregate.

The surface shall be dry prior to, during, and after installation of tack coat and fabric. Wet fabric shall be dried prior to placement of asphalt concrete.

Tack Coat

Tack coat shall be between 300 and 375 degrees Fahrenheit when applied, and will be applied at a rate of 0.22 to 0.28 gallons per square yard as directed by the Engineer. Tack coat spills or drools from the spray truck shall be heated and removed. Excess tack coat shall be covered with No. 30 sand.

Tack coat application may be verified by removing application inspection panels from the completed installation. The Contractor shall facilitate the testing. Where such testing panels are removed, the fabric shall be patched by the Contractor by hand applying tack coat and hand placing fabric pieces. The fabric repair areas

shall be 6 to 12 inches beyond the cut out area. The fabric patch shall be seeded with hot mix prior to allowing trucks or paving equipment over the patches.

Tack coat shall be allowed to cool to 200 degrees Fahrenheit or less prior to the placement of fabric.

Fabric Installation

Fabric laps shall be two minimum to four inches maximum. The fabric shall be installed a maximum of 12 inches from the curb or gutter lip. The Contractor shall either provide a combination of roll widths to meet this requirement or shall hand trim the fabric during installation.

In Cul de Sacs, the fabric shall be hand laid in the bulbs parallel to the centerline and trimmed to be no more than 12 inches from the gutter lip. For hand laid areas, the fabric shall be completely hand broomed to seat the fabric. If the fabric is not completely seated, the fabric shall be rolled with a pneumatic roller prior to paving. On returns at cross streets, the fabric shall be laid in the full return and trimmed such that it is within 12 inches of the curb and laps do not exceed 4 inches.

Where the fabric is placed over new pavement which extends the full width of the pavement, it shall lap over new asphalt concrete a minimum of twelve inches. This does not apply to digouts.

If the pavement configuration requires that the fabric be laid manually, the fabric shall be placed in increments of thirty feet or less.

Pavement fabric shall be placed with a minimum of wrinkles. If the gather wrinkle is 1/2 inch or more, cut the wrinkle and apply additional tack coat and sand blotter if necessary. The presence of more than a few wrinkles shall be cause for rejecting the fabric installation. Rejected areas of fabric shall be relaid and seated with a pneumatic roller without additional tack coat.

Installed fabric is to be protected from damage by trucks, the paving machine, and other construction equipment.

Small quantities of sand or asphalt concrete may be spread to protect the fabric during installation.

Payment shall be measured per square yard and as marked in the field by the Engineer. The fabric quantity shall be measured only the fabric covered area not including overlaps. Roll counts shall not be a basis of payment.

The contract unit cost shall be considered full compensation for furnishing all labor, materials, tools, equipment, transportation, and incidentals; and for performing all of the work involved as detailed in the Standard Specifications, these Technical Specifications, and typical sections. No additional compensation will be allowed therefore.

4. ASPHALT KEYCUT (Bid Item Number 5-6)

a. Item Requirement

Contractor shall furnish all necessary supervision, labor, materials, construction tools and equipment to complete asphalt removal and proper disposal at locations specified by the Engineer.

b. Scope

Asphalt shall be keycut prior to AC overlay. Keycut type A shall consist of longitudinal wedge cut of 0.17' by 6' (minimum). Keycut type B shall consist of a traverse wedge cut of .17' by 15 feet (minimum). The locations to key cut include, but are not limited to, any which abut any permanent structures such as curbs, concrete curbs, sidewalks, driveways, concrete slabs, speed bumps and catch basins. All other utilities such as manholes and water valves shall be raised. Grinding shall be in conformance with Section 42-2 of the Standard Specifications. Any sections of asphalt that becomes loose after keycutting shall be removed and recycled by the Contractor at the Contractor's expense.

Conform grinding will be necessary at the beginning and ending of each street section such that the final asphalt surface provides a smooth transition to the adjacent existing surface. Conform grinding shall be fifteen feet (15') wide.

Cold milling/wedge cutting machines shall be operated so as not to produce fumes or smoke. They shall be capable of planning/milling/wedge cutting the pavement without requiring the use of a heating device to soften the pavement during, or prior to, the cutting operation.

The Contractor shall be responsible for maintaining all wedge cuts, using cutback or other methods to prevent tire and suspension damage to vehicles and to prevent hazards to bicyclists and pedestrians. If wedge cuts extend into a bike lane, the contractor shall close the bike lane and place advanced warning signs in conformance with the California MUTCD.

Wedge cutting at corners, returns and hard to get areas shall be done with special grinding equipment capable of grinding such areas. Wedge cutting or grinding may encounter existing paving fabric on previously overlaid streets. No additional payment will be made for this condition. The same method shall be used on all structures that are left above the traveled asphalt surface (such as utility vaults).

Key cuts shall include the removal of excess asphalt concrete materials or slurry seals on the surface of gutters, cross gutters or other concrete surface which abut the pavement surface. The asphalt concrete or slurry materials shall be removed by methods which do not damage, stain or chip the existing concrete surfaces. Heating with a torch and scraping with hand tools such as shovels is acceptable.

When wedge cutting against standing curbs, the contractor shall either provide equipment which can cut to within 1 inch of the curb face or hand chip away the pavement between the edge of grinding and the curb face.

Schedule

Pavement key cut shall not be allowed more than 48 hours prior to schedule overlay operations without written authorization from the Engineer.

c. Measurement & Payment

Asphalt keycut shall be measured by the lineal foot and as marked in the field by the Engineer. No payment shall be made for materials removed outside of the limits marked by the Engineer. The contract unit prices paid for asphalt keycut shall include full compensation for furnishing all labor, material, equipment, tools, and all other incidentals necessary to perform the full scope of work as described above, for removal, legal disposal or as specified herein and as directed by the Engineer including the removal of excess materials from the gutter or other concrete surfaces.

5. ASPHALT REMOVAL – DIG OUT (Bid Item Numbers 7)

a. Item Requirement

Contractor shall furnish all necessary supervision, labor, materials, construction tools and equipment, supplies to complete asphalt removal and proper disposal, at bid item depths, at each location marked by the Engineer.

b. Scope

Areas designated by the Engineer shall be removed by asphalt milling to a depth of 6 inches at locations marked by the Engineer.

Failed pavement to be removed is to be ground with an asphalt grinder to the limits marked and to the depth required of the area removed.

The Contractor shall make all arrangements for disposal of excavated materials. Excavated materials will contain asphalt concrete and may contain paving fabric. The Contractor shall lawfully dispose of the removed material off the project limits. All grinding materials, where practical, are to be loaded directly in to trucks,

stockpiling of materials onsite for any time length is not allowed. Disposal shall be the responsibility of the Contractor and is considered incidental to this bid item. The location of the disposal site must be approved by the Engineer.

The material remaining in place, after removing surfacing and in some circumstances, base to the required depth, shall be graded to a plane, watered, and compacted to 95 percent relative compaction. After compaction and prior to the placing of asphalt concrete, the vertical edges of the existing pavement shall receive a tack coat. Tack coat shall be SS-1 type using penetration grade 100-200 liquid asphalt base applied at the rate of 0.10 gallons per square yard, unless otherwise directed by the Engineer. The finished surface of the remaining material shall not extend above the grade established by the Engineer.

Unsuitable Material - In the event that the underlying subbase material is unsuitable, it shall be excavated below the depth required above and disposed of. The limits of removal shall be designated by the Engineer and shall be in one-inch increments. Compensation shall be at a per inch price based on the bid for a 6 inch deep asphalt digout divided by 6 for each additional inch of depth.

Unsuitable material is defined as material the Engineer determines to be:

- a. Of such unstable nature as to be incapable of being compacted to specified density using ordinary methods at optimum moisture content; or
- b. Too wet to be properly compacted and circumstances prevent suitable in-place drying prior to incorporation into the work; or
- c. Otherwise unsuitable for the planned use.

Locations of asphalt to be removed have been field marked. Any existing improvements damaged by the Contractor's asphalt digout operation shall be replaced at the Contractor's sole expense.

c. Measurement & Payment

Measurement and Payment: "Asphalt Removal – Digout 6 inches shall be measured by the square yard and as marked in the field by the Engineer. No payment shall be made for materials removed outside of the limits marked by the Engineer. The contract unit prices paid for "Asphalt Removal – Digout 6 inches shall include full compensation for furnishing all labor, material, equipment, tools, sweeping, and all other incidentals necessary to perform the full scope of work as described above, for removal, legal disposal or as specified herein and as directed by the Engineer including temporary striping and delineation, tack coats and paint binders.

6. ADJUST UTILITY IRON (Bid Item Numbers 8-13)

a. Item Requirement

This work shall consist of raising or adjusting existing utility facilities such as manholes, valve boxes, sewer clean-outs, monument boxes, and

monitoring well covers to the finish grade of the resurfaced asphalt pavement.

Facilities located in areas to be cold planed or keycut shall be lowered first and then adjusted to finish grade after completion of the resurfacing work. At various locations a monument box and cover shall be installed at finish grade over any unprotected, existing monument in the paved roadway.

All such work shall conform to the applicable provisions of the State of California, Department of Transportation, Standard Specifications (Caltrans) dated 2010; these Technical Provisions; typical sections; and as directed by the Engineer.

b. Scope

CONSTRUCTION

Notification

Non-city owned utilities exist within the limits of construction and may be included in the quantity for adjusting utility covers to grade as part of this contract. If this work is included, the Contractor shall be responsible for contacting owners of non-city owned utilities seven (7) days prior to beginning the resurfacing work to inform them of the construction schedule. Non-city owned utilities may include, but not be limited to, San Jose Water Company, California Water Company, Cupertino Sanitary District, Sunnyvale Sanitary District, PG & E, and Pacific Bell/AT&T.

Preparation

The Contractor shall properly locate and tie all existing facilities to be raised in advance of paving operations. Each facility is to have a minimum of two tie off points. A copy of all utility cover tie-down measurements for each utility cover on each street in the project shall be supplied to the City representative prior to the commencement of any resurfacing work.

Protection of Facilities

Prior to lowering operations, sanitary and storm systems shall be protected by plywood covers. Plywood covers shall be a minimum of 1/2" thick, cut to fit the inside of the manhole, and remain in the manhole until all work is complete. Other facilities are to commensurately be protected from falling debris.

Care shall be taken to keep frames and covers clean. The Contractor shall completely protect with heavy plastic or other suitable material all utility

covers or other items which are visible on the surface and will be covered by his operations. This shall be completed prior to the start of operations and approved by the Engineer. Any materials that adhere to the frames and covers shall be removed.

Temporary Patching

On streets to be cold planed or keycut, all utility covers within the planing limit shall be lowered prior to milling.

Lowered utility lids shall be temporarily patched using a cold-patch asphaltic material. Patches shall be made to be flush with the adjacent pavement surface.

Contractor shall keep on hand sufficient patching material to continuously maintain all patches and correct any which shift or otherwise deteriorate prior to milling. Shifted or dislodged patches which constitute a drop of .10 feet or greater shall be repaired in the same day that the problem is brought to the Contractor's attention.

Adjustment

Facilities damaged by the Contractor shall be replaced at the Contractor's expense. Facilities (box and lid or frame and cover) found existing in a damaged condition, and reported to the Engineer before disturbing, shall be replaced by the Contractor with materials furnished by the Owner.

Tolerances

The concrete around adjusted facilities shall be left 1-1/2 inches lower than the adjacent pavement. The concrete surface shall be tack coated with 0.10 gallons per square yard and paved with 3/8 inch Type A HMA. Immediately after placement, the surface shall be sand sealed. Excessive sand on the surface after sealing shall be removed by the Contractor, as directed by the City Engineer.

The surface of the adjusted facilities shall be true to the new pavement surface to within 1/8 inch deviation. This tolerance shall apply in a single direction only, either up or down. In addition, the adjusted facility shall not vary to the high tolerance on one side and the low tolerance on the other (i.e. the total aggregate tolerance on both sides shall be limited to the 1/8 inch variation). This variation shall apply to the adjacent patch paving around the facility as well, such that neither the paving nor facility vary by more than the stated tolerances.

Schedule

All facilities shall be adjusted to finish grade within 72 hours after the placement of the final surface paving on each individual street segment. If several lifts of pavement are to be placed, the facilities shall be raised if the paving operation ceases for more than 72 hours.

Survey Monuments

Prior to work, contractor shall locate buried monuments using a metal detector. Where new survey monument boxes and covers are required, the Contractor shall perform the installation without disturbing the location of the monument. If the monument is disturbed the Contractor will be responsible for re-establishing it as a monument in accordance with State laws. The work for placement of the box and cover over an existing monument will include removal and replacement of the asphalt concrete around the monument.

Monitoring Wells

Where monitoring wells are to be overlaid, the location of the wells shall be marked on the curbs. A site sketch shall be provided to the city indicating the location and distances on the monitoring wells relative to the curb markings five days prior to paving. If the monitoring wells have frames and covers, the frames and covers shall be adjusted as part of this work and paid for as a valve cover.

c. Measurement & Payment

Lowering facilities shall be measured and paid for by each unit as designated in the contract Bid Schedule. Raising or adjusting facilities to finish grade shall be measured and paid for by each unit designated in the contract Bid Schedule. All quantities will be determined from actual counts. The unit costs shall govern regardless of the method used to make the adjustments.

The above contract unit costs shall be considered full compensation for furnishing all labor, materials, tools, equipment, transportation, and incidentals; and for performing all of the work involved as detailed in the Standard Specifications, these Technical Specifications, and the plans and typical sections. No additional compensation will be allowed.

Failure to adjust utility facilities within 72 hours after placement of the surface course shall result in at liquidated damage of \$250 per facility location per calendar day.

7. ASPHALT STRIPING / MESSAGES & MARKERS (Bid Item Numbers 14-35)

a. Item Requirement

The Contractor shall furnish and apply traffic stripes, characters, arrows, pavement markers, and other delineations and markings. These shall be reapplied in the original pattern on all roads except as directed by the Traffic Engineer. Additional striping changes may be requested by the Traffic Engineer. Contractor shall install traffic striping and markers in accordance with Sections 84 and 85, 'Traffic Stripes and Pavement Markings' and 'Pavement Markers' and the most recent version of the California MUTCD. All striping details shall conform to Caltrans Standard Plans, latest addition. All pavement Markers and Traffic Lines shall conform to details as revised July 21, 2017 or latest revision.

All pavement legends and traffic striping shall be applied in thermoplastic unless otherwise noted.

Temporary pavement marking materials must be on hand prior to the covering or demolition of existing pavement markings.

b. Scope

MATERIALS

Pavement Delineation- Thermoplastic

Thermoplastic material shall be extruded thermoplastic meeting the requirements of Section 84-2 and specifically Section 84-2.03B Extruded Thermoplastic or City approved equivalent. Placement shall be performed as directed by the manufacturer.

Legends and arrows shall be pre-formed thermoplastic pavement markings and shall be Ennis Flint Premark or a City approved equivalent. Placement shall be performed as directed by the manufacturer.

Pavement Delineation- Pavement Markers

Raised and reflective pavement markers shall comply with Section 85 of the Standard Specifications. The specific type to be used shall be consistent with the type generally in use within the local jurisdiction unless directed otherwise by the Engineer.

Preformed Thermoplastic Green Bike Lane including bike symbols, legends and arrows.

Green bike lanes shall be preformed thermoplastic pavement markings and shall be Premark ViziGrip Skid/Slip Resistant (90 mil) or a City approved equivalent. Bike symbols, legends, and arrows within green bike lanes and shall be Premark ViziGrip (90 mil) or a City approved equivalent. Placement shall be performed as required by the manufacturer's specifications.

Bike symbols, legends, and arrows in green bike lanes must be factory assembled with the green marking sheet and interconnected so that in the field it is unnecessary to assemble the individual pieces within a material segment.

The green bike lanes shall be pre-formed thermoplastic pavement marking sheets utilizing light green color that meets FHWA specifications for color.

A sealer specified by the manufacturer must be applied to the substrate asphalt and concrete to ensure proper adhesion.

Preformed green marking sheets shall be installed first before the 6" white liquid thermoplastic bicycle lane line. Pre-formed sheets shall be laid out and applied so that edges of adjacent sheets fit snugly together, the pattern of the marking aligns properly from sheet to sheet, and to prevent overlap of adjacent sheets.

First time applicators shall contact the pre-formed thermoplastic pavement marking supplier for product support and on-site training.

CONSTRUCTION

All construction shall conform to the respective provisions of the Standard Specifications, manufacturer's installation requirements, and these Technical Specifications.

Existing Striping and Markings

In areas adjacent to the pavement resurfacing or striping enhancements, where existing striping must be changed to conform to a revised striping pattern, conflicting striping shall be removed by sand blasting, grinding, or other methods as specified in the Standard Specifications or by the Engineer.

The Contractor shall replace all striping which has been damaged or obliterated by or during the work. This may include striping replacement completely across the street even in the event that the Contractor's work may not extend that far. Both lines of each crosswalk shall be completely repainted even if only a portion of a line has been obliterated.

Layout for Temporary and Permanent Striping

The alignment and layout of traffic stripes shall conform to the Standard Specifications.

The Contractor shall perform all tie downs, layout, alignment, and spotting. Contractor shall submit a plan documenting location, dimensions, and Caltrans Standard Detail reference number or other applicable detail for all existing pavement striping, markings, markers and legends. The plan shall contain sufficient detail for installation of new thermoplastic and markers. The plans shall be submitted prior to the pre-construction meeting and shall be approved by the Engineer prior to the issuance of Notice to Proceed. The Engineer or his/her designee shall review and approve striping layout prior to final striping.

The Contractor shall physically tie down the location of the beginning and ending of each paint or thermoplastic marking type in the adjacent curb top. The marking location shall not exceed fifty square inches each. Any locations exceeding this limit shall be removed by the Contractor prior to acceptance of the work. The Contractor shall contact the City Traffic Division for review of tie downs.

The Contractor shall be responsible for accurately referencing out and replacing the lines and positions of all traffic lines, directional lines, arrows, and other markings in accordance with either prior existing striping/message layout or by revised striping plans provided by the Engineer by cat tracking with painted marks. This shall occur no later than two hours after the final surface course paving operation.

Cat tracking shall consist of stretching a rope on a straight line between control points on tangent alignment and on a true arc through control points on curved alignment and placing spots of paint along the rope. Temporary tab markers shall be placed not more than twelve feet apart on curves nor more than twenty-four feet apart on straight segments.

Temporary tab markers shall be the same color as the traffic stripe that they are replacing, shall measure two inches tall by 3-1/2 inches wide, and have a reflective lens across the width of the marker.

Application of cat tracking and/or placement of temporary tab markers are to occur immediately upon completion of final compaction rolling and prior to opening asphalt areas to traffic. All crosswalks, stop bars and directional arrows, both yellow and white in color, shall be placed immediately upon completion of final compaction rolling and prior to opening asphalt areas to traffic. Cat tracking shall be complete and ready for City review by the sixth

calendar day following paving. Failure to comply with these requirements shall result in a liquidated damage of \$500 per day for each street that has not received temporary installation of the tab markers, traffic striping, and other markings or completion of cat tracking. All liquidated damages in this Contract are cumulative.

Prior to application of permanent striping and markers, the Contractor shall call for review and approval of the proposed striping by the Engineer or his/her designee. The City shall have the right to make changes in the location and alignment of line stripes. Striping and traffic markings shall not be applied until approval is granted by the Engineer or his/her designee. The Contractor shall allow a minimum of seven working days for review of the layout by the City.

Crosswalks

In some instances, portions of new crosswalks will extend beyond limit of pavement rehabilitation work. In these instances, the existing 12 inch wide lines outside the paving limit shall be removed by grinding or sandblasting prior to placing new crosswalk striping.

At various locations in the project, crosswalks shall be consist of a series of ten (10) foot width by two (2) foot length bars, with no perpendicular lines at the crosswalk sides, as shown in the 'Miscellaneous Details & City Standard Details' of the Contract Documents.

Schedule

Raised pavement markers (RPM's) shall be placed to replace existing RPM's or as designated by City provided striping plans. When utilizing hot melt bituminous adhesive, RPM's shall be placed after the surface has been open to traffic for at least seven days. When utilizing epoxy adhesive, RPM's shall be placed after the surface has been open to traffic for at least fourteen days. Regardless of which adhesive is utilized, the RPM's shall not be placed more than twenty-one days after paving or surfacing.

Thermoplastic materials shall be placed to replace existing thermoplastic materials or as designated by City provided striping plans. Permanent traffic striping and markings including legends and arrows shall be placed between fourteen (14) and twenty-one (21) days after paving or surfacing, unless otherwise directed by the Engineer. **All permanent striping shall be complete in place by the 22nd day after completion of resurfacing work. All permanent striping on streets near schools shall be installed prior to August 11, 2018.** See Attachment A for list of streets near schools.

Reflective and Raised Pavement Markers

Installation of both reflective and raised pavement markers shall conform to the provisions of Section 85 of the Standard Specifications. Pavement markers shall be placed in the same pattern and locations as they were previously, except as specified by the Engineer.

Reflective Pavement Markers at fire hydrants shall consist of placing a single blue marker on the new pavement surface. Location of the new marker shall be six (6) inches off of the lane striping nearest to and in line with the existing fire hydrant.

Pavement Delineation- Thermoplastic

Pavement temperature shall be measured at the beginning of the shift on each working day and this information shall be provided to the Traffic Engineer.

No primer or thermoplastic shall be installed within forty-eight hours from the last measurable rain report as provided by the City.

Thermoplastic traffic striping, legends, and arrows shall conform to the provisions of Section 84-of the Standard Specifications and these Technical Provisions.

c. Measurement & Payment

Payment for traffic striping layout and placement of temporary lane markers will be included in the unit price bid for each striping detail as identified in the Bid Schedule and no additional compensation will be allowed therefore.

Measurement and payment for pavement striping, characters, arrows, pavement markers, raised pavement markers, and reflective pavement markers shall be paid on a unit cost basis as identified in the Bid Schedule.

Payment for any striping removal as identified herein shall be included in the unit price for the related striping item and no additional compensation will be allowed therefore.

The above contract unit costs shall be considered full compensation for furnishing all labor, materials, tools, equipment, transportation, and incidentals; and for performing all of the work involved as detailed in the Standard Specifications, these Technical Specifications, and the plans and typical sections. No additional compensation will be allowed therefore.

8. TRAFFIC SIGNAL LOOPS (Bid Item Number 36)

a. Item Requirement

Work to be performed under this Section covers all labor, materials, tools, equipment, transportation, and incidentals necessary to replace existing loop detectors at various street intersections. It is anticipated that all the existing loop detectors at the intersections will be damaged by the proposed pavement cold planing.

b. Scope

All replaced signal loops shall be Standard 6'x 6' rectangular loops as shown on plans and details unless specifically called out otherwise. Any changes to loop type, placement pattern, or installation may be performed only as allowed by the Engineer.

All such work shall conform to the details and provisions of the State of California, Department of Transportation's Standard Plans and Section 86, "Electrical Systems," of the Standard Specifications and these Technical Provisions, except that Subsection 86-8, "Payment," is modified herein.

Intersection Locations

All left turn lane and through lane detector loops, including advance lane loops, shall be replaced to their existing locations, or as shown in plans provided by the City and to the details provided in these contract documents.

The proposed locations of the replaced signal loops detectors shall be marked in the field and approved by the Engineer prior to installation.

Maintaining the traffic signals during construction shall be a part of this work. The maximum time between disconnecting loops in operation until replacement shall be 14 working days. Failure to meet this schedule will cause the work to be performed by City forces and the Contractor backcharged for the work.

Construction

All traffic loops shall be replaced after approval of cat tracking and prior to final striping.

Prior to initiating any work on the signal loops, the Contractor shall mark in the field location of new loops according to the plans and details. The City Traffic Division shall be contacted to review locations as marked by contractor. Loop installation operations shall commence only after approval is granted by Traffic Engineer.

Advance warning loops shall be installed 200 feet from limit line, as outlined in Table 9-1 'Suggested Detector Setbacks from Limitline' in the State Traffic Manual.

Pull Boxes

Where the sump of an existing pull box is disturbed by the Contractor's operations, the sump shall be reconstructed and, if the sump was grouted, the old grout shall be removed and new grout placed.

Detectors

Loop wire shall be Type II.

In Lieu of the requirements in the fourth paragraph of Section 86-5.01A(5), "Installation of Details," of the State Standard Specifications, slots in asphalt concrete pavement shall be filled as follows:

After conductors are installed in the slots cut in the pavement, paint binder shall be applied to all vertical surfaces of slots in accordance with the provisions in Section 94, "Asphaltic Emulsions," of the State Standard Specifications. The slots shall then be filled with asphaltic concrete sealants using hot melt loop sealant.

Temperature of sealant material during installation shall be above 70 degrees F. Air temperatures during installation shall be above 50 degrees F. Hot melt sealant placed in the slots shall be compacted by use of an 8-inch diameter by 1/8-inch thick steel hand roller or other tool approved by the Engineer. Compacted sealant shall be flush with the pavement surface. Minimum conductor coverage shall be 5/8 inch. Excess sealant remaining after rolling shall not be reused. Traffic may be released immediately over compacted material.

The Contractor shall test all detectors with a motor-driven cycle, as defined in the California Vehicles Code, that is licensed for street use by the Department of Motor Vehicles of the State of California. The unladen weight of the vehicle shall not exceed 220 pounds and the engine displacement shall not exceed 100 cubic centimeters. Special features, components or vehicles designed to activate the detector will not be permitted. The Contractor shall provide an operator who shall drive the motor-driven cycle through the response or detection area of the detector at not less than 3 miles per hour nor more than 7 miles per hour.

Detectors will be disconnected or connected by the Contractor. The Contractor shall notify the Engineer 24 hours prior to any detector being

disconnected or connected. Timing adjustments shall be made by City traffic personnel.

Schedule

Traffic signal loops damaged due to grinding, cold planing, digouts, paving or any other related construction shall be replaced within 2 weeks following the damage.

c. Measurement and Payment

The measurement and payment for replacing loop detectors, complete in place and operable, will be made at the unit bid price for each loop as listed in the bid schedule.

The unit price and payment shall include full compensation for furnishing all labor, materials, tools, equipment, transportation and incidentals, and for doing all the work involved in replacing the loop detectors, complete, as specified in these Technical Specifications.

8. SPEED BUMPS (Bid Item 37)

a. Item Requirements

Remove existing speed bumps prior paving. Install new speed bumps at existing location per City Standard detail 1-17A, modified to remove the width of section B-B equals 12 feet, eliminating the 10 foot flat section. The profile of new speed bumps shall match existing.

Schedule

New speed bumps shall be installed a minimum of 5 calendar days and a maximum of 10 calendar days following final paving.

9. AC Dike (Bid Items 38&39)

a. Item Requirement –

The contractor shall furnish and install Type D or Type E Asphalt Dike in accordance with Caltrans Standard Detail A87B, Section 2 of Section 00850 of these specifications and section 39 of the State Standard Specifications (2010).

b. Payment

Payment shall be per lineal foot.

10. REMOVE EXISTING 4" SHOULDER/REPLACE WITH 4" HMA (Bid Item 40)

a. Item Requirement –

The Contractor shall saw cut a straight edge along the existing pavement. If removal is by cold planer, the cold planed edge is acceptable. The existing shoulder material shall be removed and graded to the elevations and limits provided during construction by the Engineer. The top 6 inches of existing subgrade shall be scarified, moisture conditioned, and compacted to 95% relative compaction. HMA shall be placed in two equal lifts and compacted per Section 2 above.

b. Payment

Payment shall be by the square foot and include all costs including providing and installing the HMA.

11. REGRADE SHOULDER (Bid Item 41)

a. Item Requirement –

After construction of the widened pavement on Orion, the Contractor shall reshape the shoulder area to drain around the corner toward the existing inlet on N. Stelling. Some material will likely have to be removed from the site. The regraded shoulder shall be watered and compacted by rolling with a small steel wheel roller and if necessary, vibraplace.

b. Payment

Payment shall be by the square foot and include all costs.

12. SHOULDER BACKING (Bid Item 42)

a. Item Requirement –

After construction of the AC berm on Crescent, the Contractor shall backfill the berm as indicated on the detail. The shoulder backing material shall be topsoil over topsoil areas and Class 2 aggregate base over gravel areas. Existing excavated material may be used if all lumps and rocks greater than 1-1/2" are removed from the surface. The shoulder backing shall be moisture conditioned and compacted using a vibraplate to 85% to 90% relative compaction for the topsoil and a minimum of 90% for the Class 2.

b. Payment

Payment shall be by the square foot and include all costs.

End Technical Specifications

TYPICAL SECTIONS AND KEY CUT DETAILS

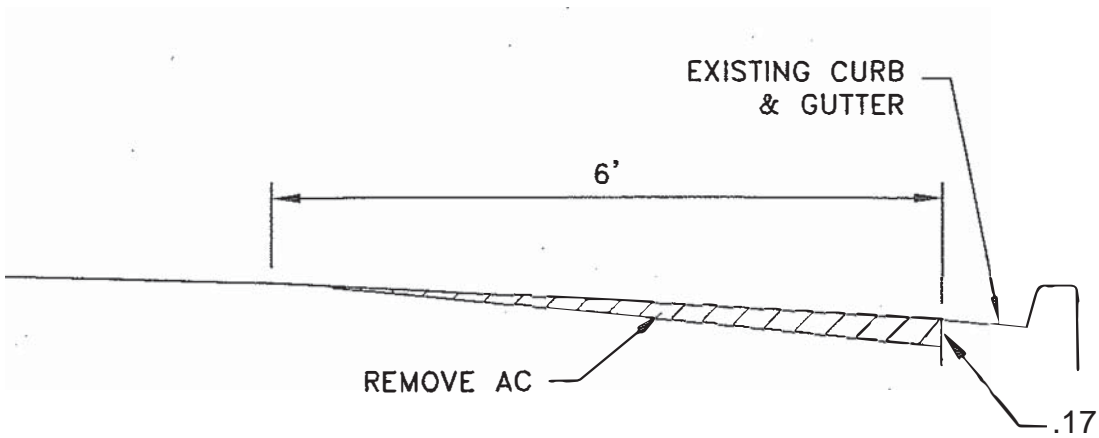

KEYCUT – TYPE A
LONGITUDINAL KEYCUT
 NTS

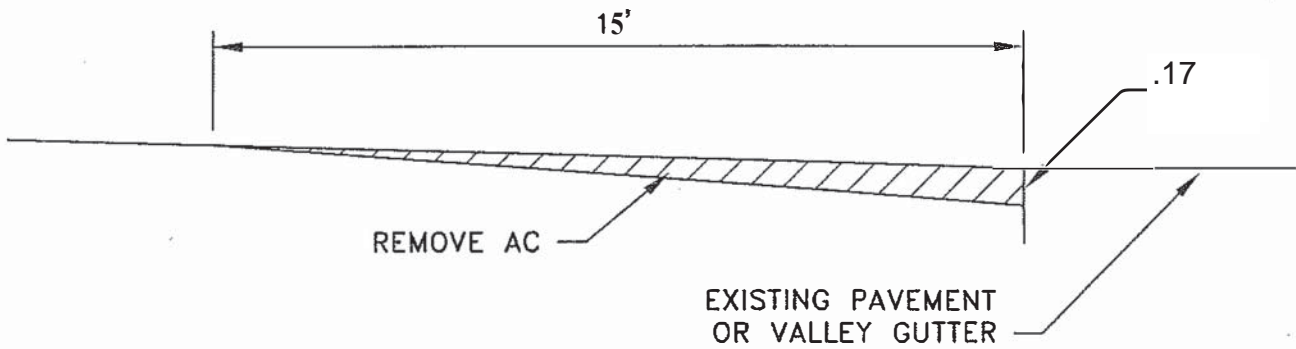

KEYCUT – TYPE B
TRANSVERSE KEYCUT
 NTS

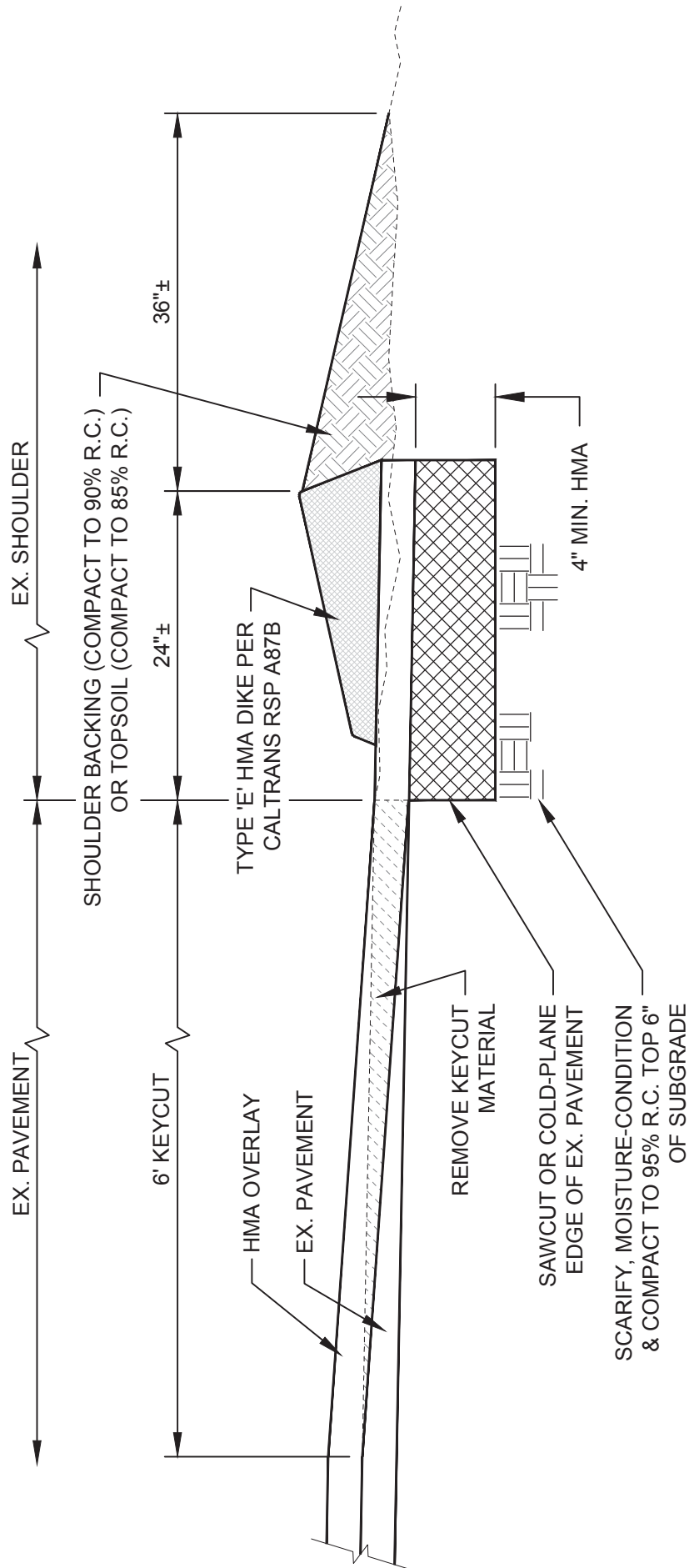

SHOULDER DETAIL ON CRESCENT ROAD

NTS

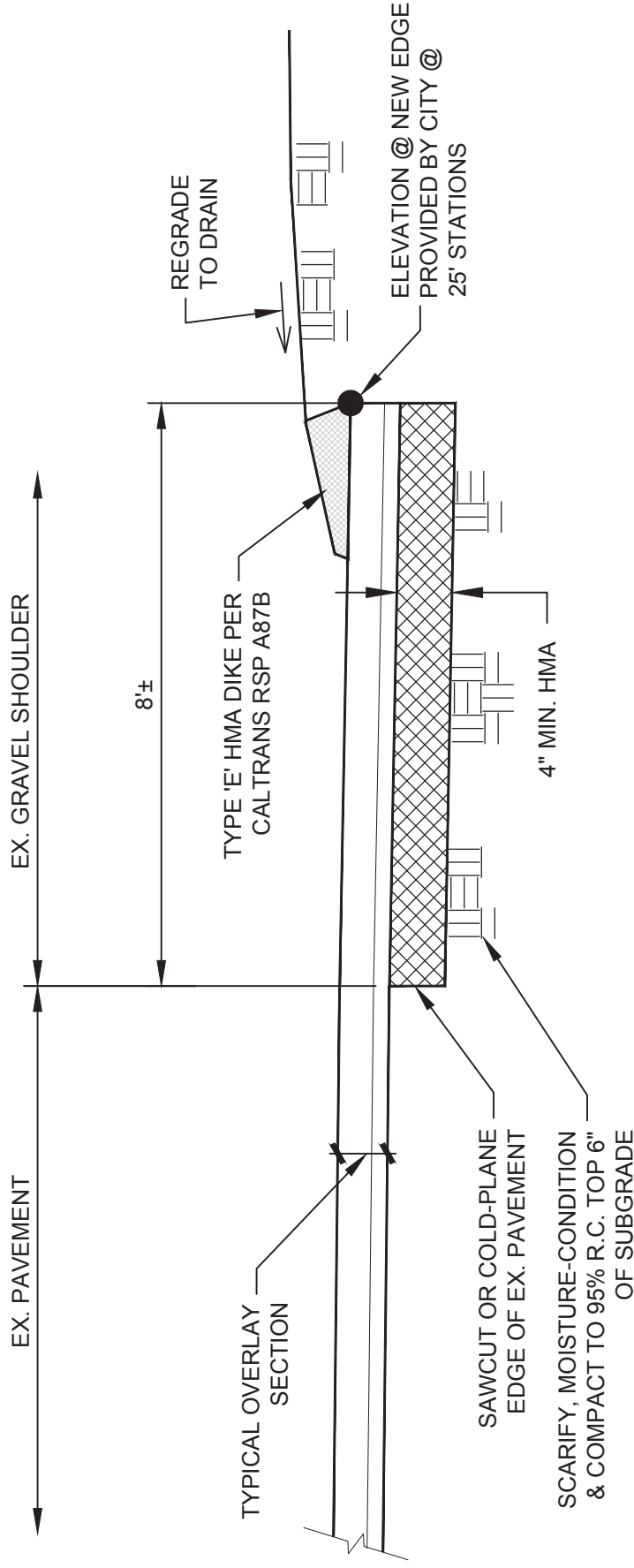

SHOULDER DETAIL ON ORION LANE

NTS

CITY STANDARD DETAILS

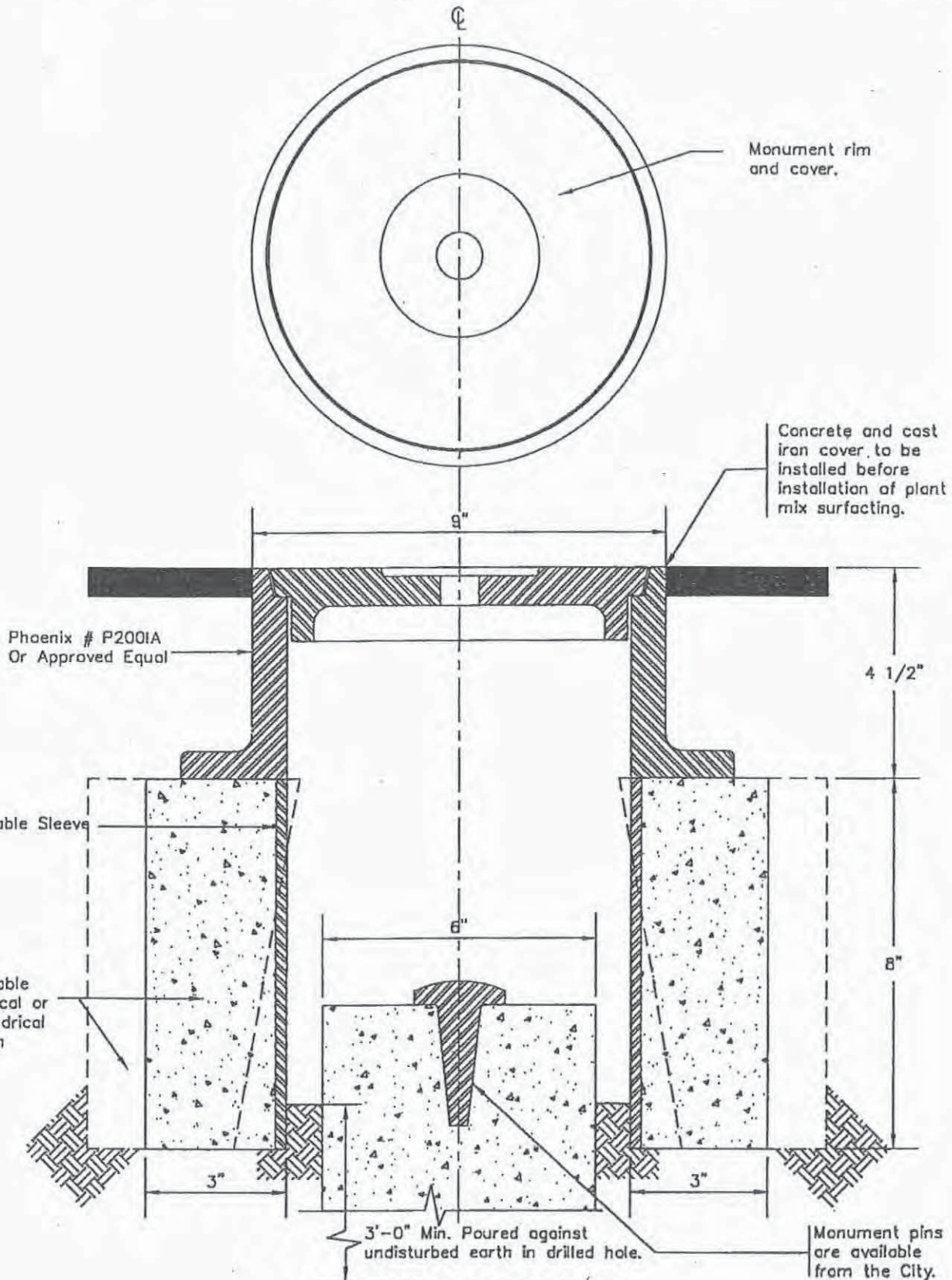

STREET MONUMENT

CITY OF CUPERTINO
STANDARD DETAILS

APPROVED BY:

[Signature]
CITY ENGINEER

DATE: 6/27/97

1-14

CONCENTRIC MANHOLE

8" to 33" PIPE

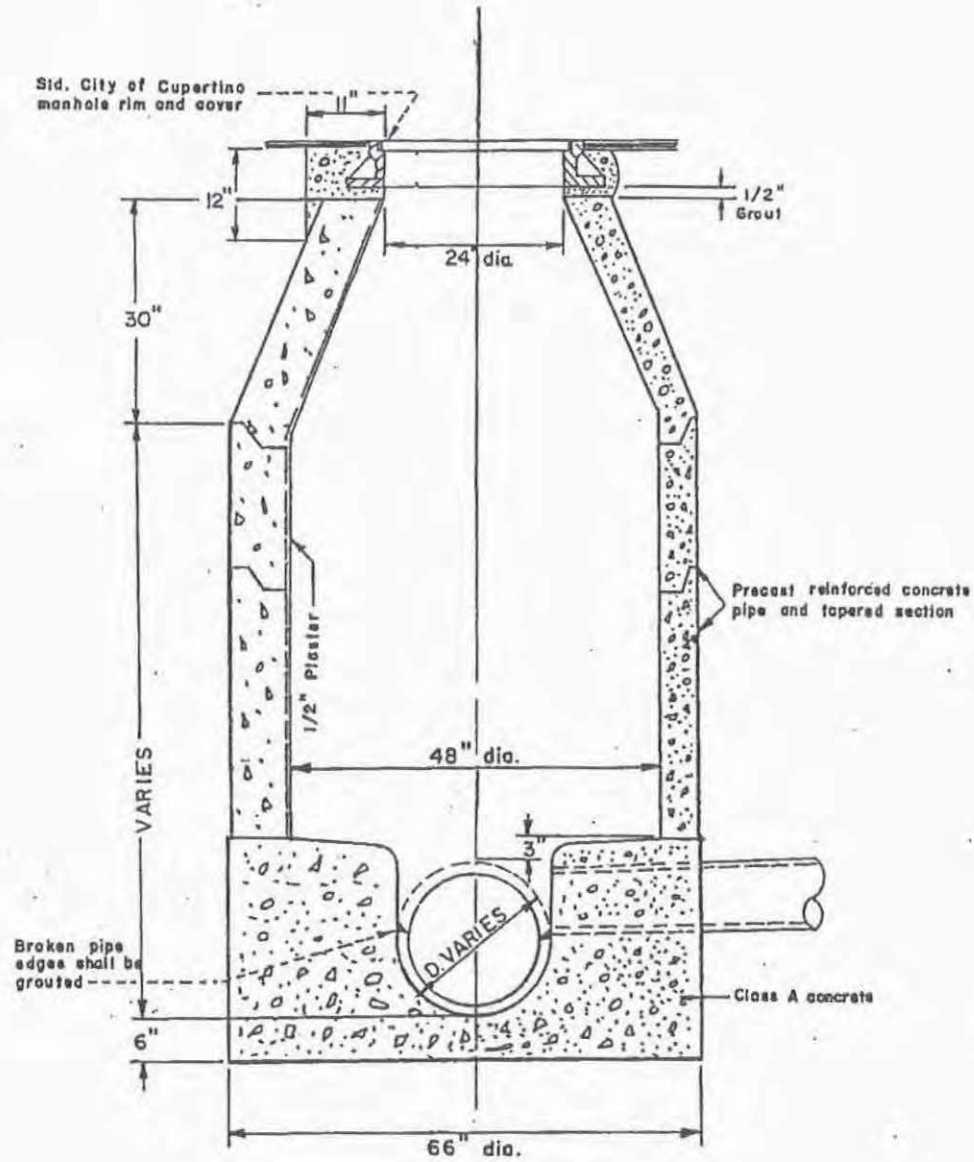

NOTES:

Mortar and grout to conform to Section 65, State Std. Specifications.

Manhole foundation poured in place.

**CITY OF CUPERTINO
STANDARD DETAILS**

APPROVED BY:

[Signature]
CITY ENGINEER

DATE:

2/10/89

3-10

W 37 (MUTCD W8-1) & W 6 (MUTCD W13-1)-15 MPH

StreetPrint Pavement Texturing
City Approved Brick Pattern & Color of Terracotta. The
paint shall be StreetPrint Traffic Formula.

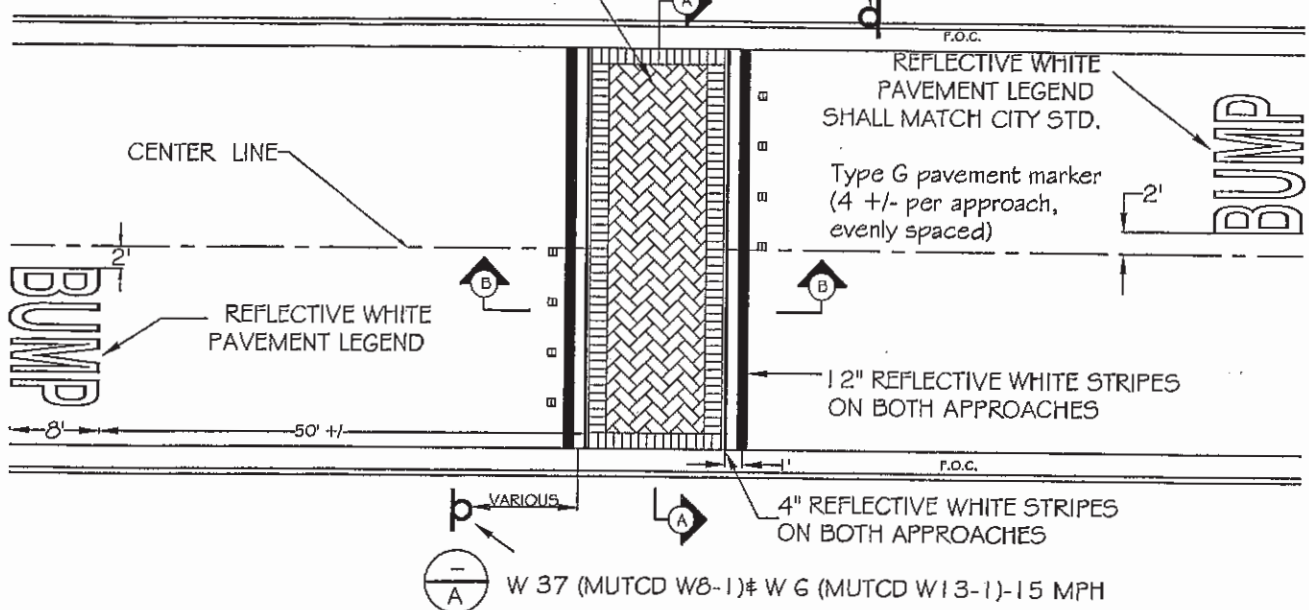

PLAN VIEW

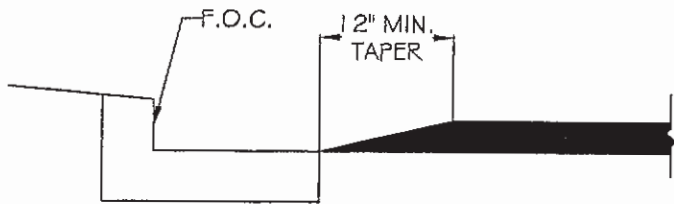

SECTION A-A



W37 (MUTCD W8-1)
(Standard 30")



W 6 (MUTCD W13-1)
(24")

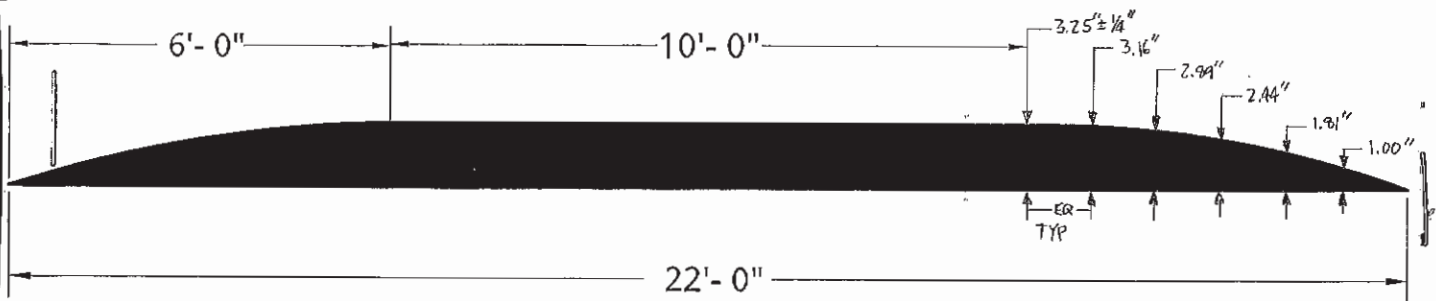

SECTION B-B

CITY OF CUPERTINO
STANDARD DETAILS

APPROVED BY:

City Engineer

DATE:

9/20/2017

1-17A

AREA #	6	6	21	2	11	27
	OVERLAY	OVERLAY	6" Dig Outs	6" Dig Outs	6" Dig Outs	GREEN BIKE LANES
UNIT	Robindell Way (Stelling to End)	Squirehill Ct (Stelling to End)	Tantau Ave (Various Locations)	Bandley Dr (Various Locations)	Bubb Rd @ McClellan (Various Locations)	N Blaney at Collins School
AREA	37,399	19,976	2,122	2,454	2,996	
LS						1
TN	112	60	0	0	0	4,107
TN	477	255	80	92	112	17,694
SY	4,155	2,220	0	0	0	151,575
LF	2100	1100	0	0	0	71,018
LF	140	70	0	0	0	5,750
SY	0	0	236	273	333	841
EA	4	4	1	0	0	155
EA	0	1	1	0	1	51
EA	0	2	0	1	0	26
EA	4	4	1	0	1	200
EA	0	2	0	1	0	29
EA	0	0	0	0	0	48
LF	0	0	0	0	0	210
LF	0	0	0	0	0	140
LF	20	20	60	0	0	1,540
LF	0	0	0	0	0	300
LF	0	0	0	80	0	410
LF	0	0	0	0	80	210
LF	0	0	0	0	0	5,550
LF	0	0	0	0	0	40
LF	0	0	0	0	0	40
EA	0	0	0	0	0	3
EA	1	1	1	0	0	39
EA	0	0	0	0	0	1
EA	0	0	0	0	0	1
EA	0	0	0	0	0	1
EA	1	0	0	0	0	11
EA	0	0	0	0	0	2
EA	0	0	0	0	0	12
SF	0	0	0	0	0	1,500
EA	0	0	0	0	0	1
EA	0	0	0	0	0	1
EA	0	0	0	0	0	1
EA	0	0	0	0	2	8
EA	0	0	0	0	8	28
EA	0	0	0	0	0	7
LF	0	0	0	0	0	150
LF	0	0	0	0	0	700